

SCHEDULE OF OPENING

| SYMBOLE | SIZE | SILL | LINTEL | REMARK |
|---------|-------------|------|--------|--------|
| (D1) | 1700 x 2000 | - | 1930 | DOOR |
| (D2) | 900 x 2000 | - | 1930 | DOOR |
| (W1) | 1000 x 1000 | 1000 | 2000 | WINDOW |



PUFF PANEL LAYOUT
SCALE:- 1:50

| | | | | | | | | | | | | | | | | | |
|----------------------|------------------|---|--------------|---|---|-----------------------|---|------------------|------------|------|-------------|------|--|--|------------------|--------------|----------------|
| DATE:- 20-05-2015 | PROJECT:- | | CLIENT:- | DRAWING:- G.A. DRAWING OF PUFF PANEL |  <p>STRUCCORE ANKIT K. PATEL C/1, JAYEN APP. , CHUNIBHAI COLONY, NR. FOOTBALL GROUND , KANKARIYA, AHMEDABAD-380022 , TEL:(M) 09723618823, ankit@strucore.com</p> | DRAWING NO: AR-1.0 | | | | | | | | | | | |
| | | <table border="1"> <tr> <td>B</td> <td>FOR CONSTRUCTION</td> <td>20-05-2015</td> </tr> <tr> <td>A</td> <td>FOR CONSTRUCTION</td> <td>21-03-2015</td> </tr> <tr> <td>REV.</td> <td>DESCRIPTION</td> <td>DATE</td> </tr> </table> | B | FOR CONSTRUCTION | | 20-05-2015 | A | FOR CONSTRUCTION | 21-03-2015 | REV. | DESCRIPTION | DATE | | <table border="1"> <tr> <td>SCALE:- AS SHOWN</td> <td>DRAWN:- K.P.</td> <td>CHECKED:- A.P.</td> <td>REVISION:- A</td> </tr> </table> | SCALE:- AS SHOWN | DRAWN:- K.P. | CHECKED:- A.P. |
| B | FOR CONSTRUCTION | 20-05-2015 | | | | | | | | | | | | | | | |
| A | FOR CONSTRUCTION | 21-03-2015 | | | | | | | | | | | | | | | |
| REV. | DESCRIPTION | DATE | | | | | | | | | | | | | | | |
| SCALE:- AS SHOWN | DRAWN:- K.P. | CHECKED:- A.P. | REVISION:- A | | | | | | | | | | | | | | |

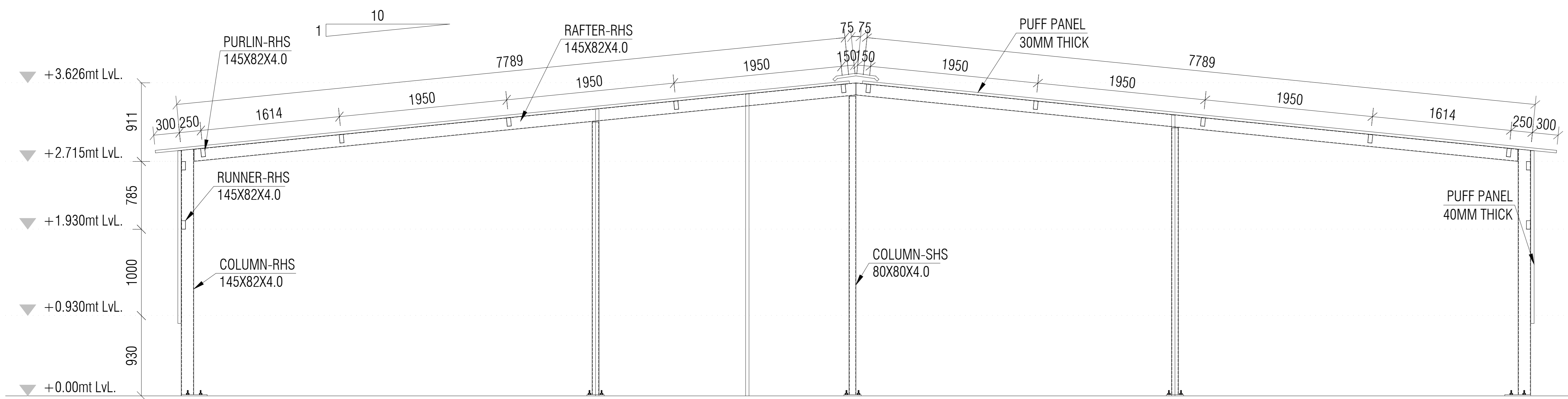

SECTION A-A
SCALE:- 1:50

| DATE:- 20-05-2015 | PROJECT:- | | | CLIENT:- | DRAWING:- TYPICAL SECTION |  | STRUCCORE ANKIT K. PATEL C/1, JAYEN APP. , CHUNIBHAI COLONY, NR. FOOTBALL GROUND , KANKARIYA, AHMEDABAD-380022 , TEL: (M) 09723618823, ankit@strucore.com | DRAWING NO: AR-2.0 | | | | | | | | | |
|----------------------|------------------|---|------|-------------|--|---|---|---------------------------------|---|------------------|------------|--|--|--|--|--|--|
| | | | | | SCALE:- AS SHOWN DRAWN:- K.P. CHECKED:- A.P. REVISION:- A | | | | | | | | | | | | |
| | | <table border="1"> <thead> <tr> <th>REV.</th> <th>DESCRIPTION</th> <th>DATE</th> </tr> </thead> <tbody> <tr> <td>B</td> <td>FOR CONSTRUCTION</td> <td>20-05-2015</td> </tr> <tr> <td>A</td> <td>FOR CONSTRUCTION</td> <td>21-03-2015</td> </tr> </tbody> </table> | REV. | DESCRIPTION | DATE | B | FOR CONSTRUCTION | 20-05-2015 | A | FOR CONSTRUCTION | 21-03-2015 | | | | | | |
| REV. | DESCRIPTION | DATE | | | | | | | | | | | | | | | |
| B | FOR CONSTRUCTION | 20-05-2015 | | | | | | | | | | | | | | | |
| A | FOR CONSTRUCTION | 21-03-2015 | | | | | | | | | | | | | | | |

SCHEDULE OF OPENING

| SYMBOLE | SIZE | SILL | LINTEL | REMARK |
|---------|-------------|------|--------|--------|
| (D1) | 1700 x 2000 | - | 1930 | DOOR |
| (D2) | 900 x 2000 | - | 1930 | DOOR |
| (W1) | 1000 x 1000 | 1000 | 2000 | WINDOW |

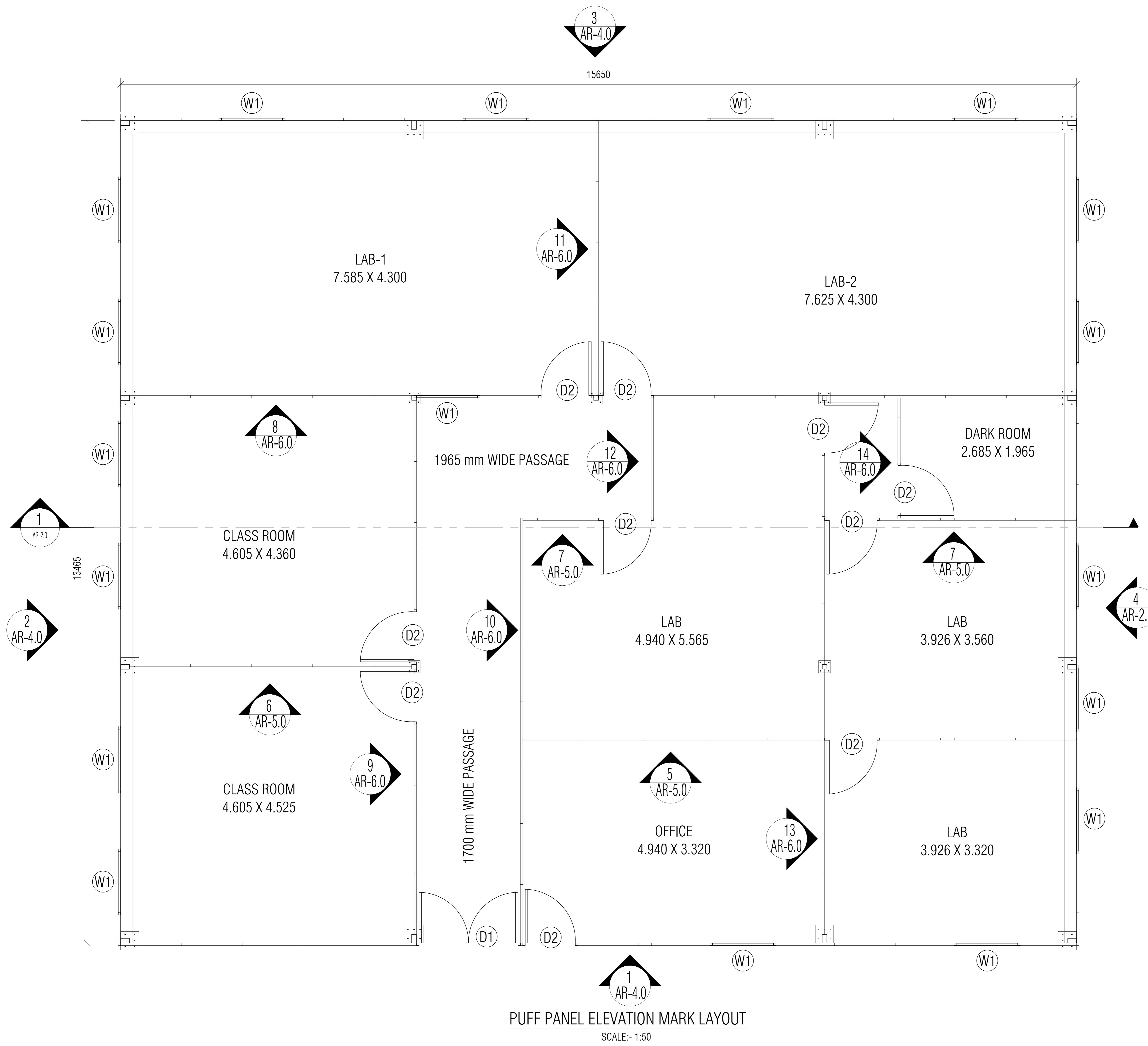

PUFF PANEL ELEVATION MARK LAYOUT
SCALE:- 1:50

| DATE:- 20-05-2015 | PROJECT:- | | CLIENT:- | DRAWING:- PUFF PANEL ELEVATION MARK LAYOUT |  <p>STRUCCORE ANKIT K. PATEL C/1, JAYEN APP. , CHUNIBHAI COLONY, NR. FOOTBALL GROUND , KANKARIYA, AHMEDABAD-380022 , TEL:-(M) 09723618823, ankit@strucore.com</p> | DRAWING NO: AR-3.0 | | | | | | | |
|----------------------|------------------|---|----------|--|--|-----------------------|---|------------------|------------|---|------------------|------------|--|
| | | | | SCALE:- AS SHOWN DRAWN:- K.P. CHECKED:- A.P. REVISION:- A | | | | | | | | | |
| | | <table border="1"> <thead> <tr> <th>REV.</th> <th>DESCRIPTION</th> <th>DATE</th> </tr> </thead> <tbody> <tr> <td>B</td> <td>FOR CONSTRUCTION</td> <td>20-05-2015</td> </tr> <tr> <td>A</td> <td>FOR CONSTRUCTION</td> <td>21-03-2015</td> </tr> </tbody> </table> | REV. | DESCRIPTION | | DATE | B | FOR CONSTRUCTION | 20-05-2015 | A | FOR CONSTRUCTION | 21-03-2015 | |
| REV. | DESCRIPTION | DATE | | | | | | | | | | | |
| B | FOR CONSTRUCTION | 20-05-2015 | | | | | | | | | | | |
| A | FOR CONSTRUCTION | 21-03-2015 | | | | | | | | | | | |

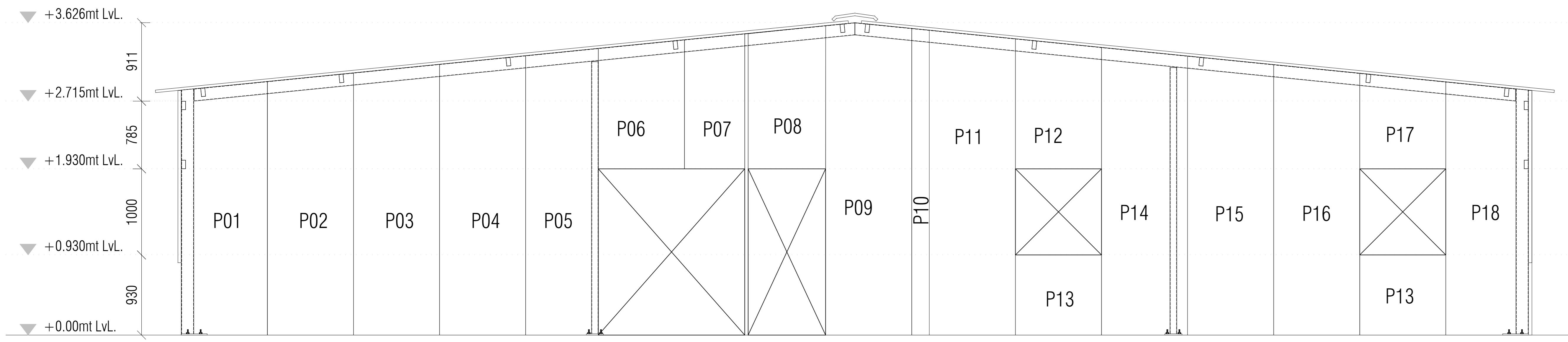

ELEVATION MARK-1
SCALE:- 1:50

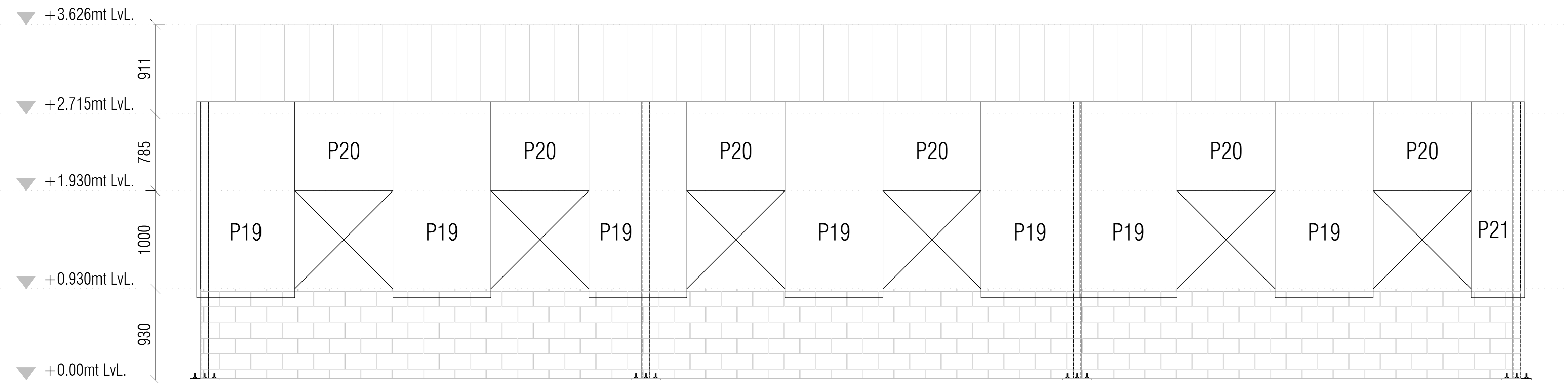
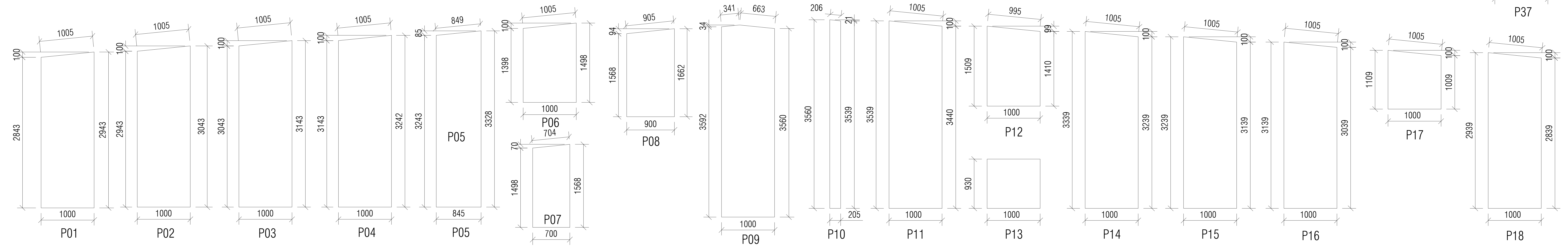
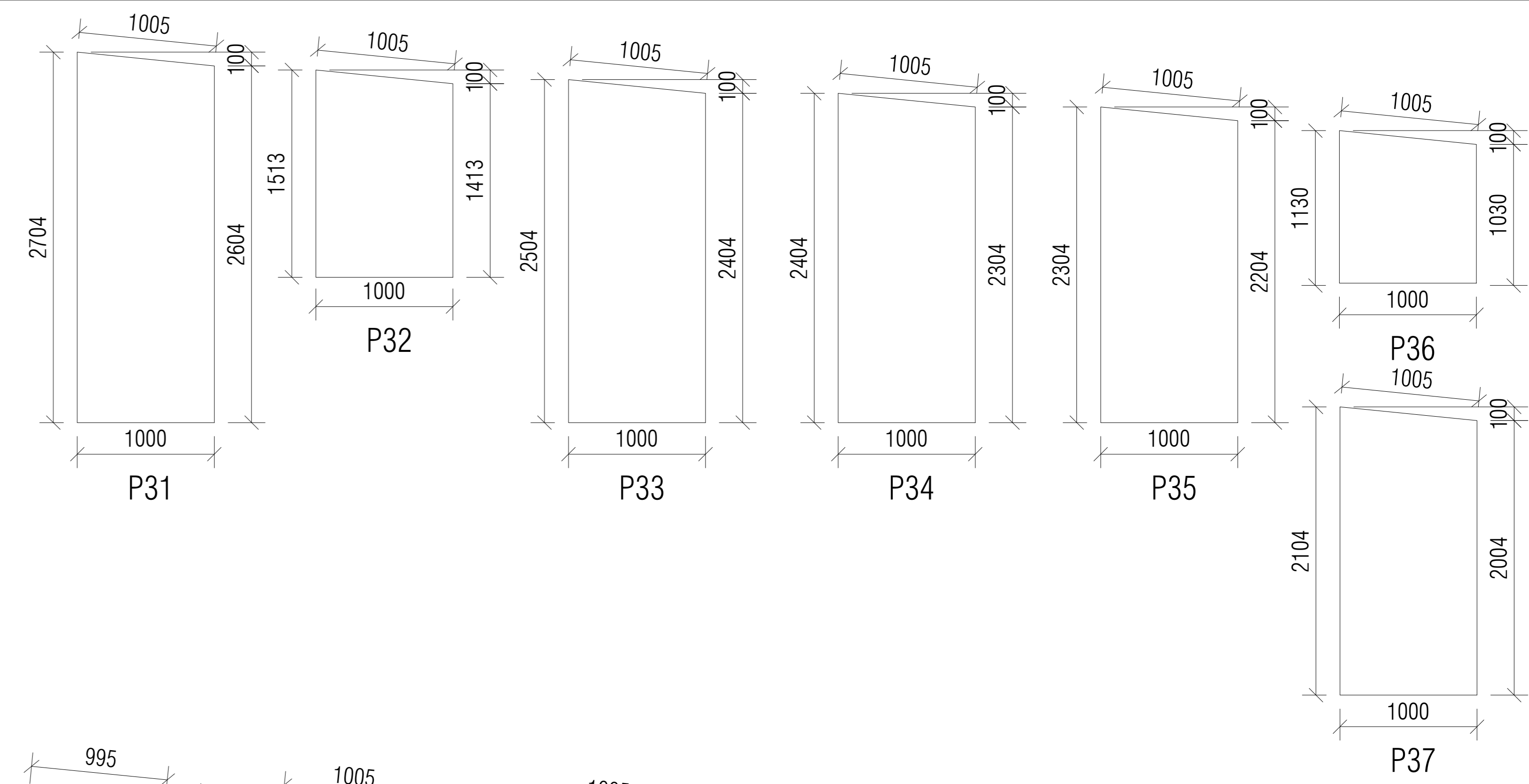

ELEVATION MARK-2
SCALE:- 1:50

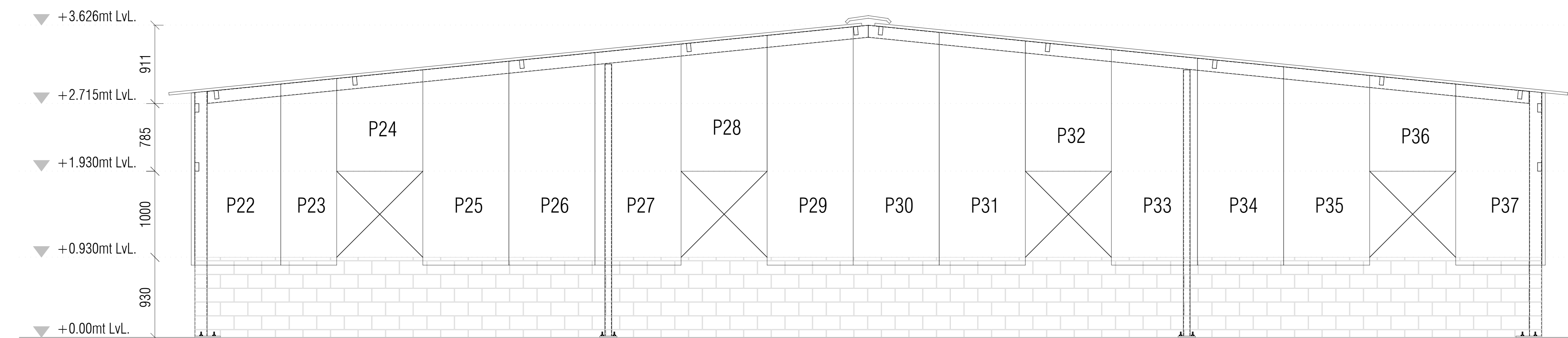
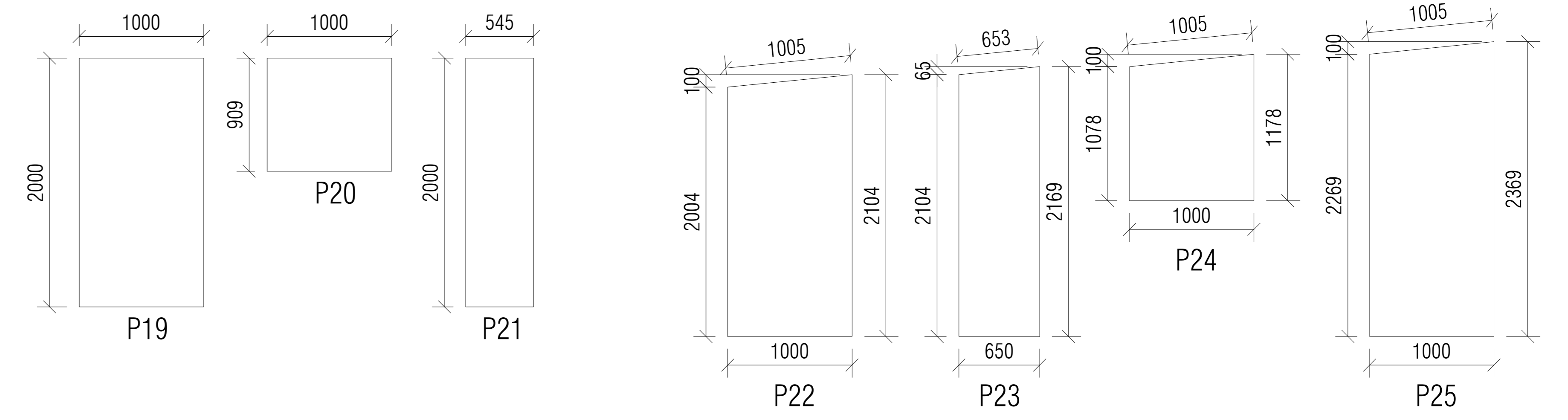

ELEVATION MARK-3
SCALE:- 1:50

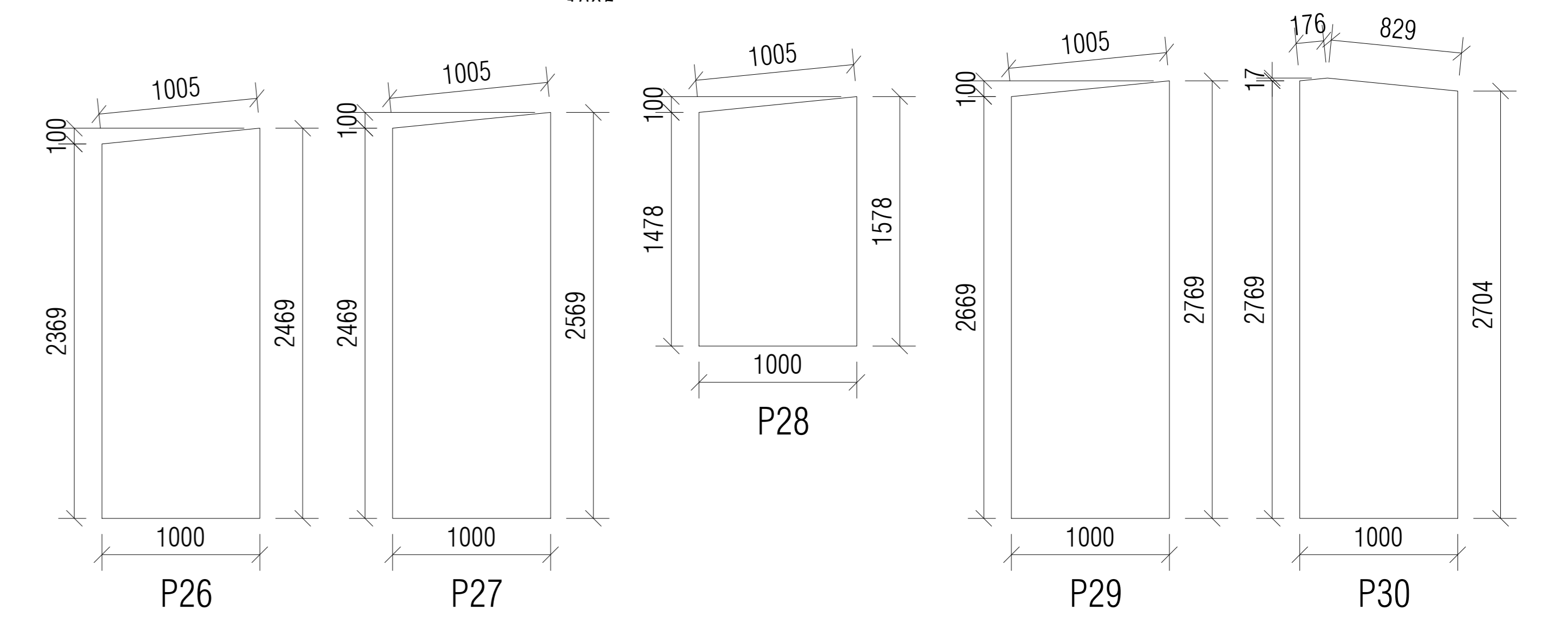

| | | | | | | | | | |
|----------------------|-----------|------|------------------|-------------------------------|--|------------------------------|--------------|----------------|--------------|
| DATE:- 20-05-2015 | PROJECT:- | | CLIENT:- | DRAWING:- ELEVATION MARK-1 |  <p>STRUCCORE ANKIT K. PATEL C/1, JAYEN APP. , CHUNIBHAI COLONY, NR. FOOTBALL GROUND , KANKARIYA, AHMEDABAD-380022 , TEL:(M) 09723618823, ankit@strucore.com</p> | DRAWING NO: AR-4.0 | | | |
| | | B | FOR CONSTRUCTION | 20-05-2015 | | SCALE:- AS SHOWN | DRAWN:- K.P. | CHECKED:- A.P. | REVISION:- A |
| | | A | FOR CONSTRUCTION | 21-03-2015 | | | | | |
| | | REV. | DESCRIPTION | DATE | | | | | |

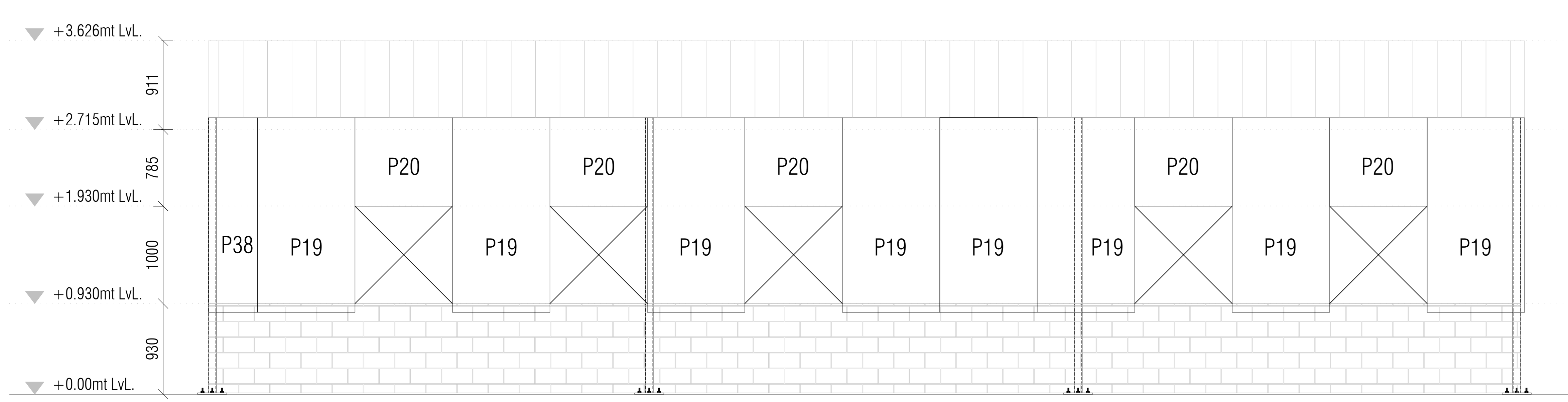

ELEVATION MARK-4
SCALE:- 1:50

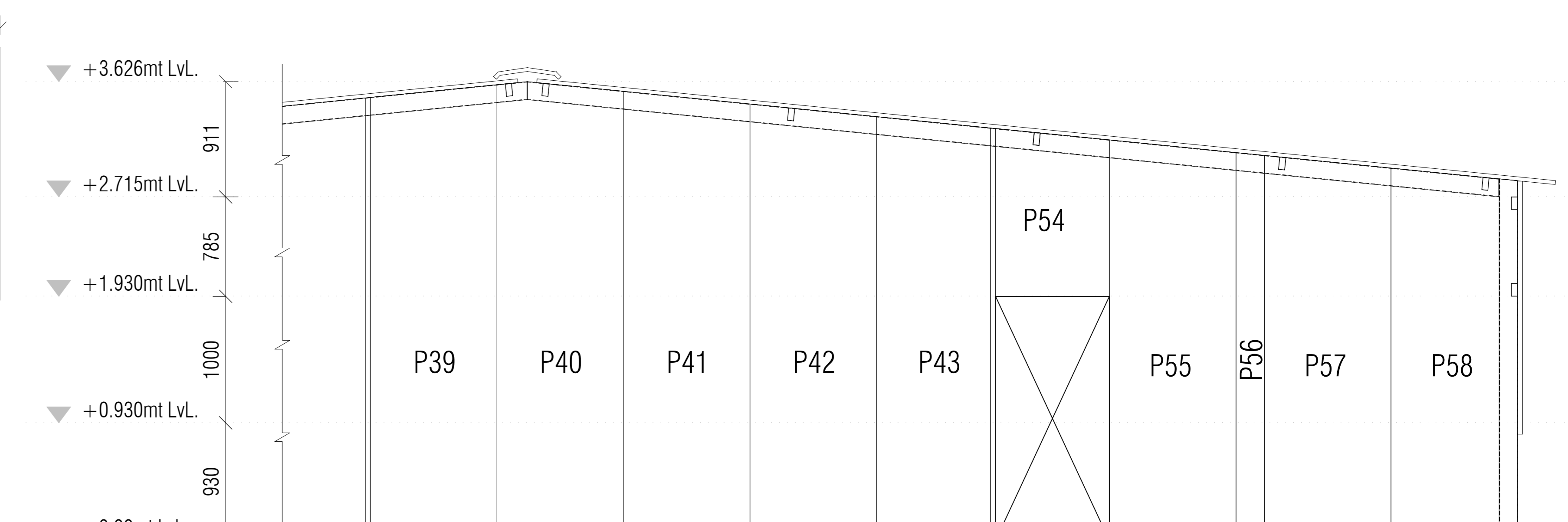

ELEVATION MARK-5
SCALE:- 1:50

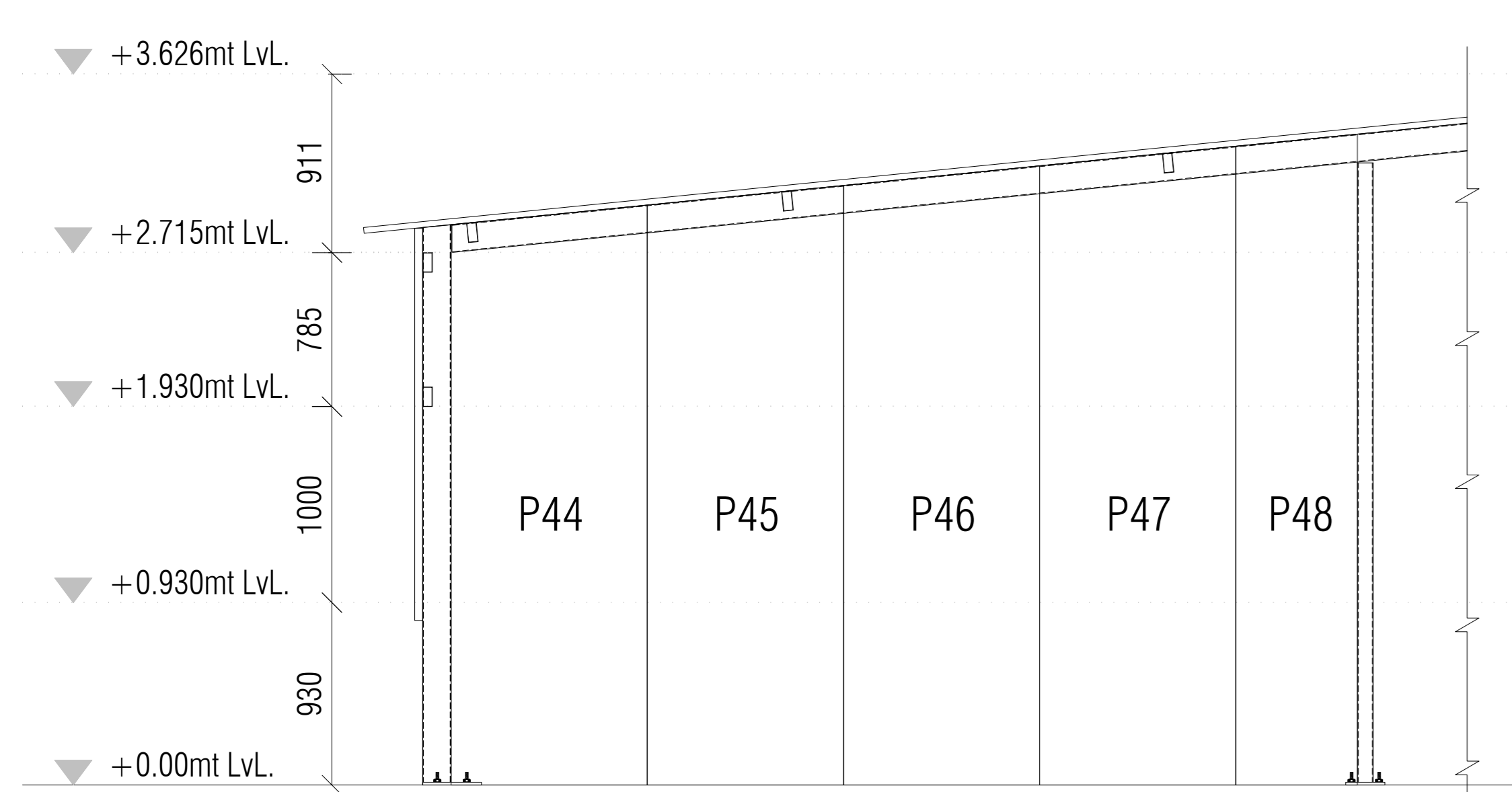

ELEVATION MARK-6
SCALE:- 1:50

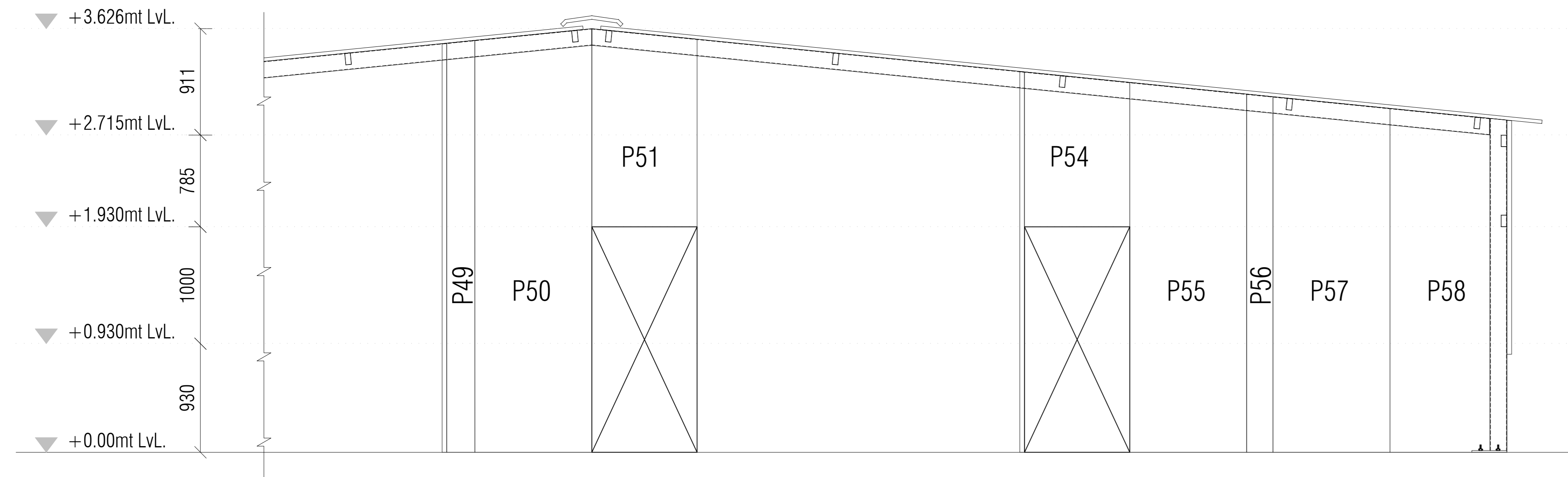
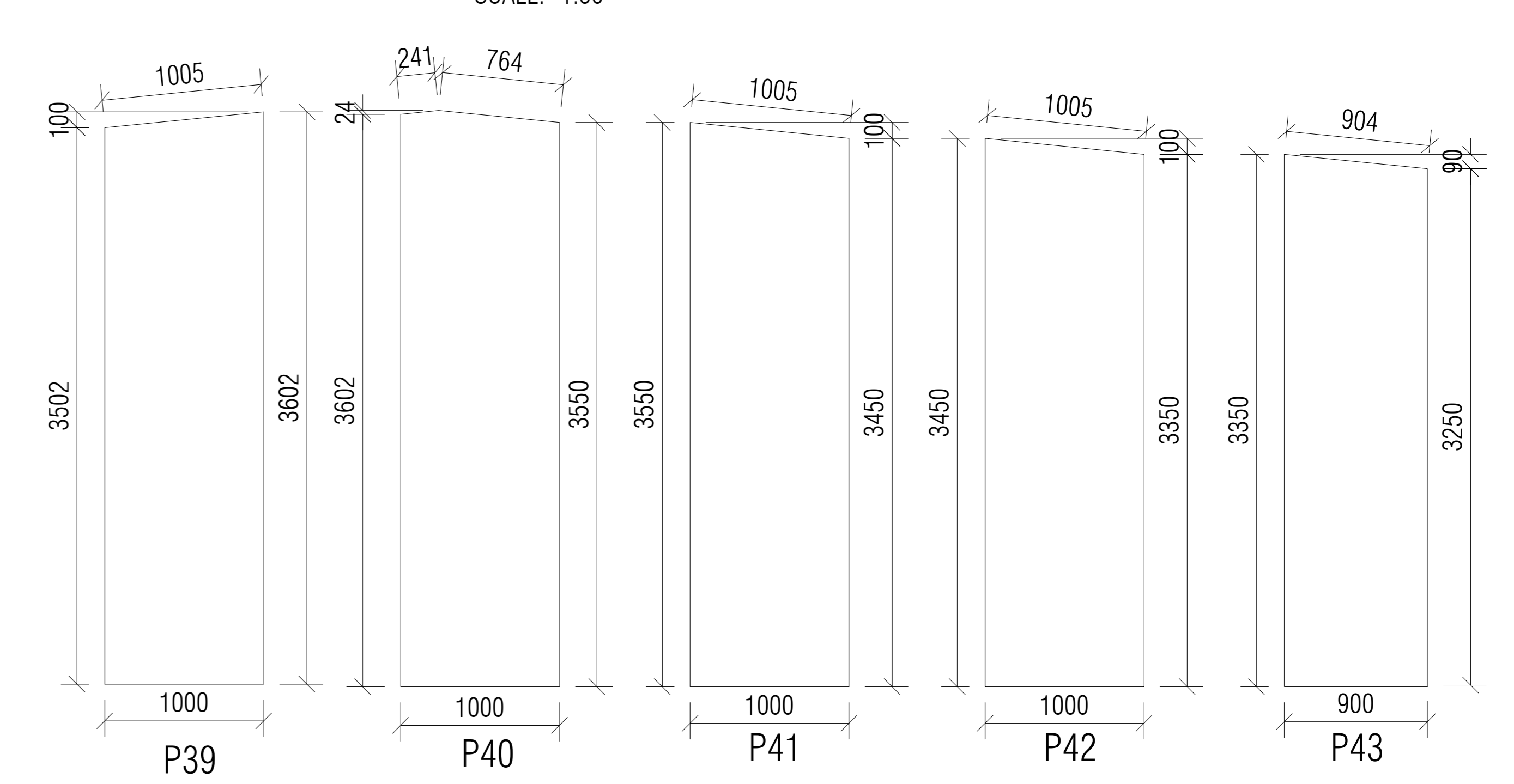
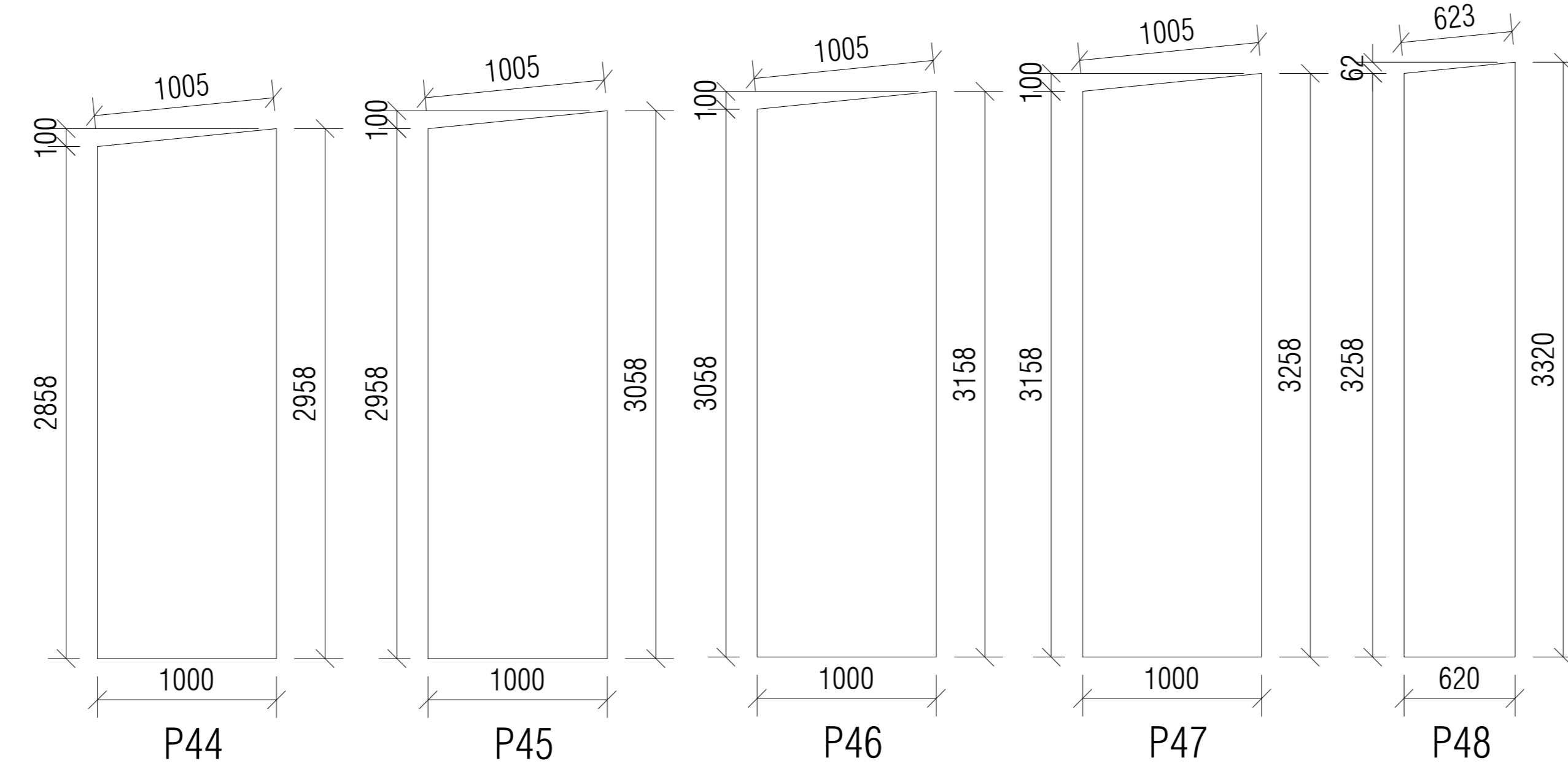

ELEVATION MARK-7
SCALE:- 1:50

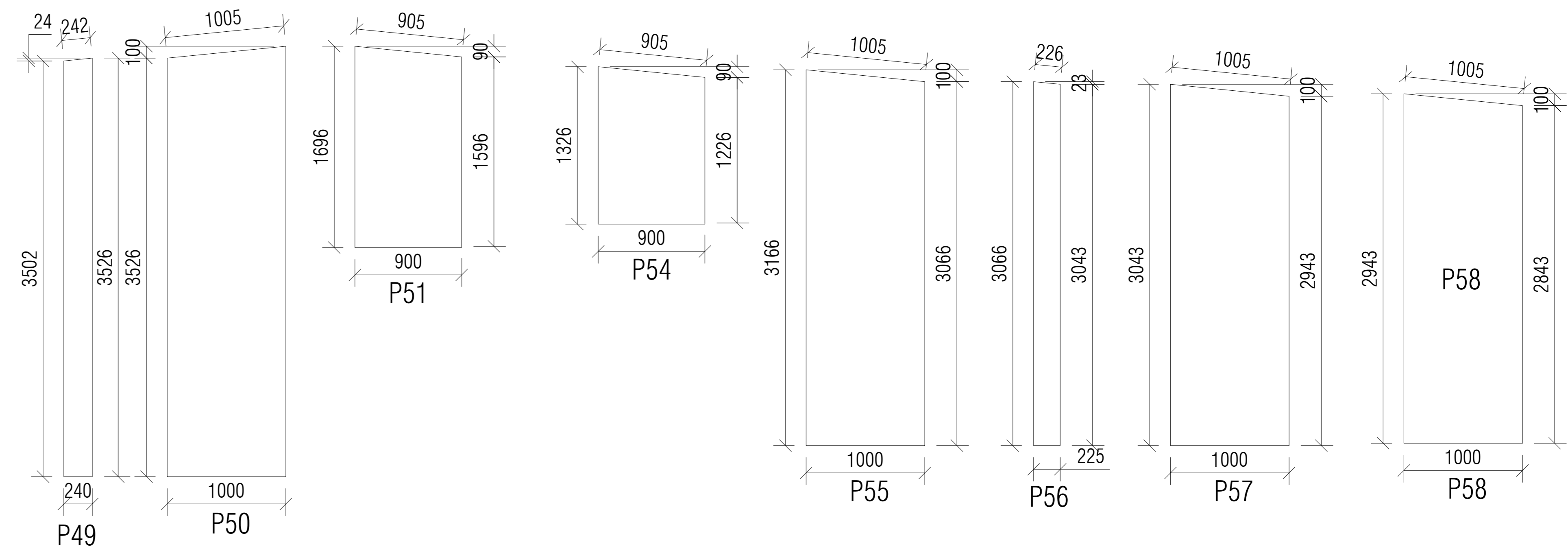

| | | | | | | | | | | | | | | | | | |
|----------------------|------------------|---|--------------|---------------------------------|---|-----------------------|---|------------------|------------|------|-------------|------|--|--|------------------|--------------|----------------|
| DATE:- 20-05-2015 | PROJECT:- | | CLIENT:- | DRAWING:- ELEVATION MARK - 2 |  <p>STRUCCORE ANKIT K. PATEL C/1, JAYEN APP. , CHUNIBHAI COLONY, NR. FOOTBALL GROUND , KANKARIYA, AHMEDABAD-380022 , TEL:-(M) 09723618823, ankit@strucore.com</p> | DRAWING NO: AR-5.0 | | | | | | | | | | | |
| | | <table border="1"> <tr> <td>B</td> <td>FOR CONSTRUCTION</td> <td>20-05-2015</td> </tr> <tr> <td>A</td> <td>FOR CONSTRUCTION</td> <td>21-03-2015</td> </tr> <tr> <td>REV.</td> <td>DESCRIPTION</td> <td>DATE</td> </tr> </table> | B | FOR CONSTRUCTION | | 20-05-2015 | A | FOR CONSTRUCTION | 21-03-2015 | REV. | DESCRIPTION | DATE | | <table border="1"> <tr> <td>SCALE:- AS SHOWN</td> <td>DRAWN:- K.P.</td> <td>CHECKED:- A.P.</td> <td>REVISION:- A</td> </tr> </table> | SCALE:- AS SHOWN | DRAWN:- K.P. | CHECKED:- A.P. |
| B | FOR CONSTRUCTION | 20-05-2015 | | | | | | | | | | | | | | | |
| A | FOR CONSTRUCTION | 21-03-2015 | | | | | | | | | | | | | | | |
| REV. | DESCRIPTION | DATE | | | | | | | | | | | | | | | |
| SCALE:- AS SHOWN | DRAWN:- K.P. | CHECKED:- A.P. | REVISION:- A | | | | | | | | | | | | | | |

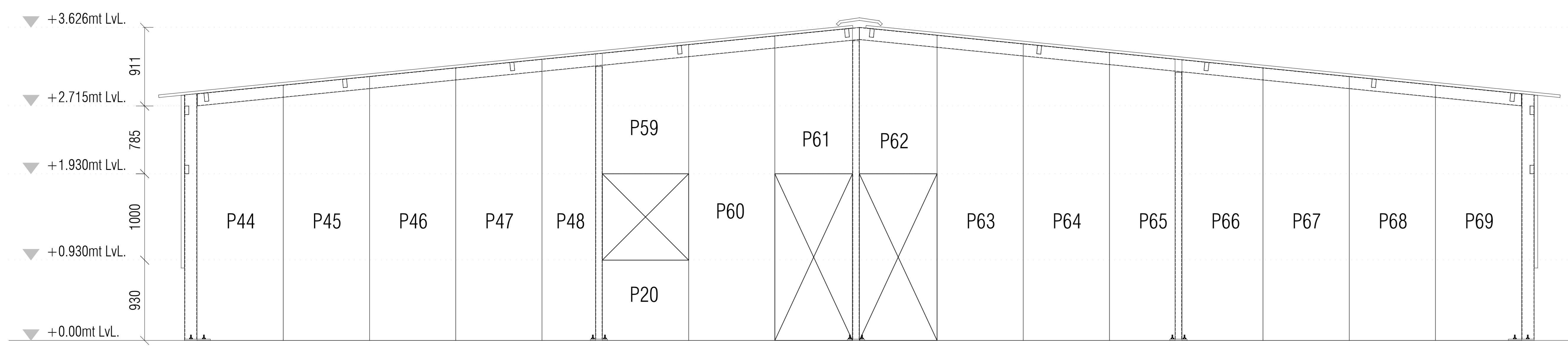

ELEVATION MARK-8
SCALE:- 1:50

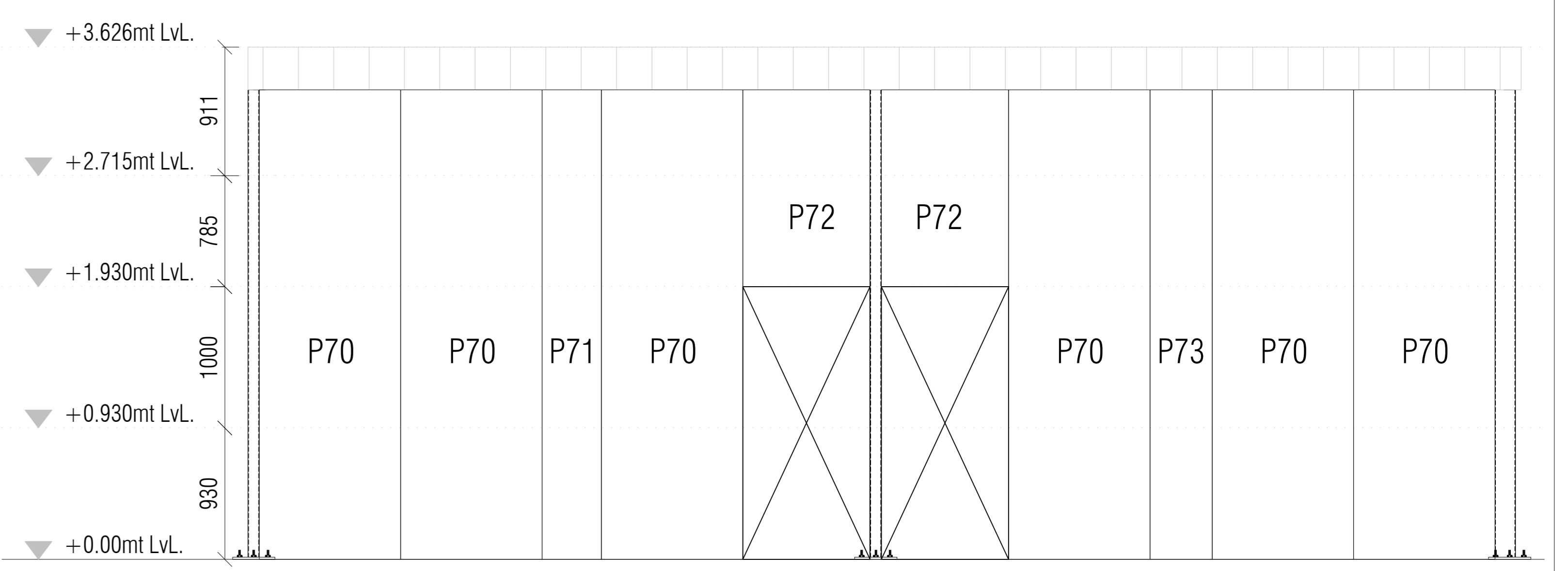

ELEVATION MARK-9
SCALE:- 1:50

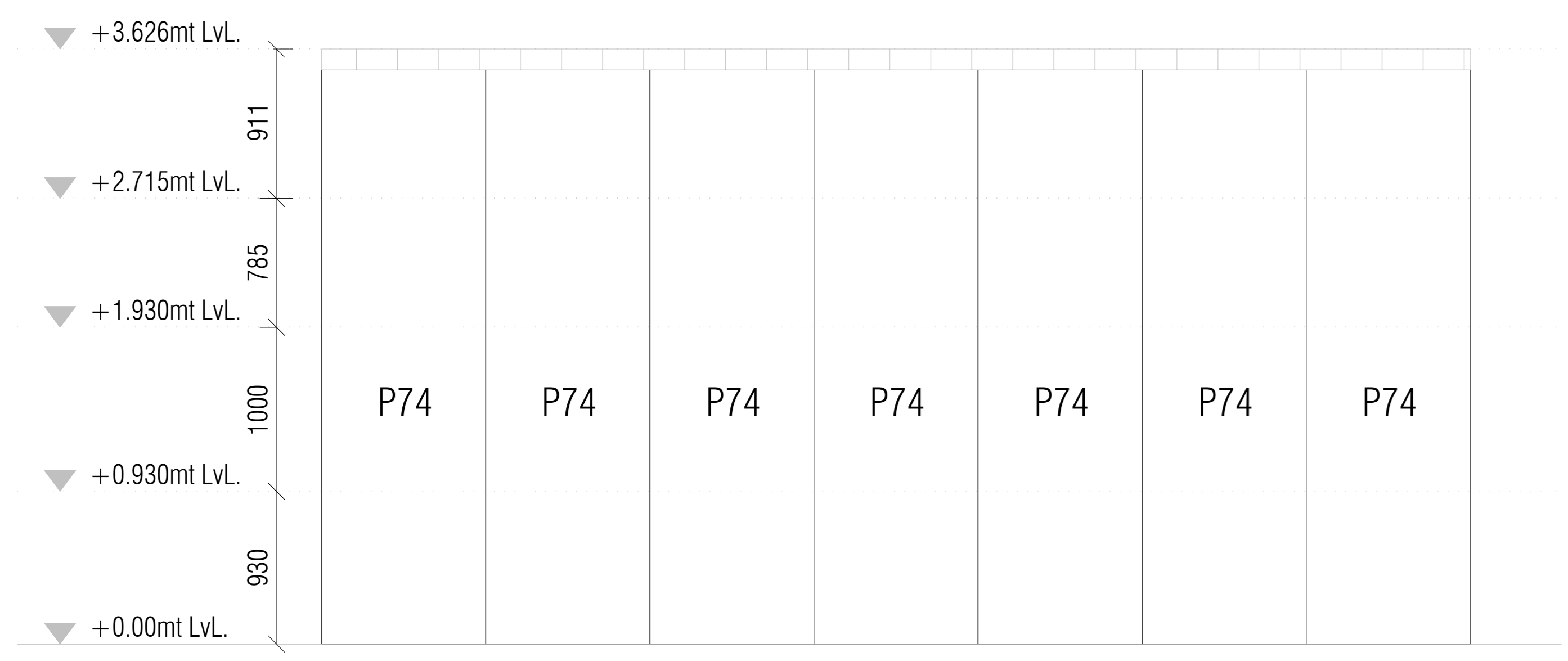
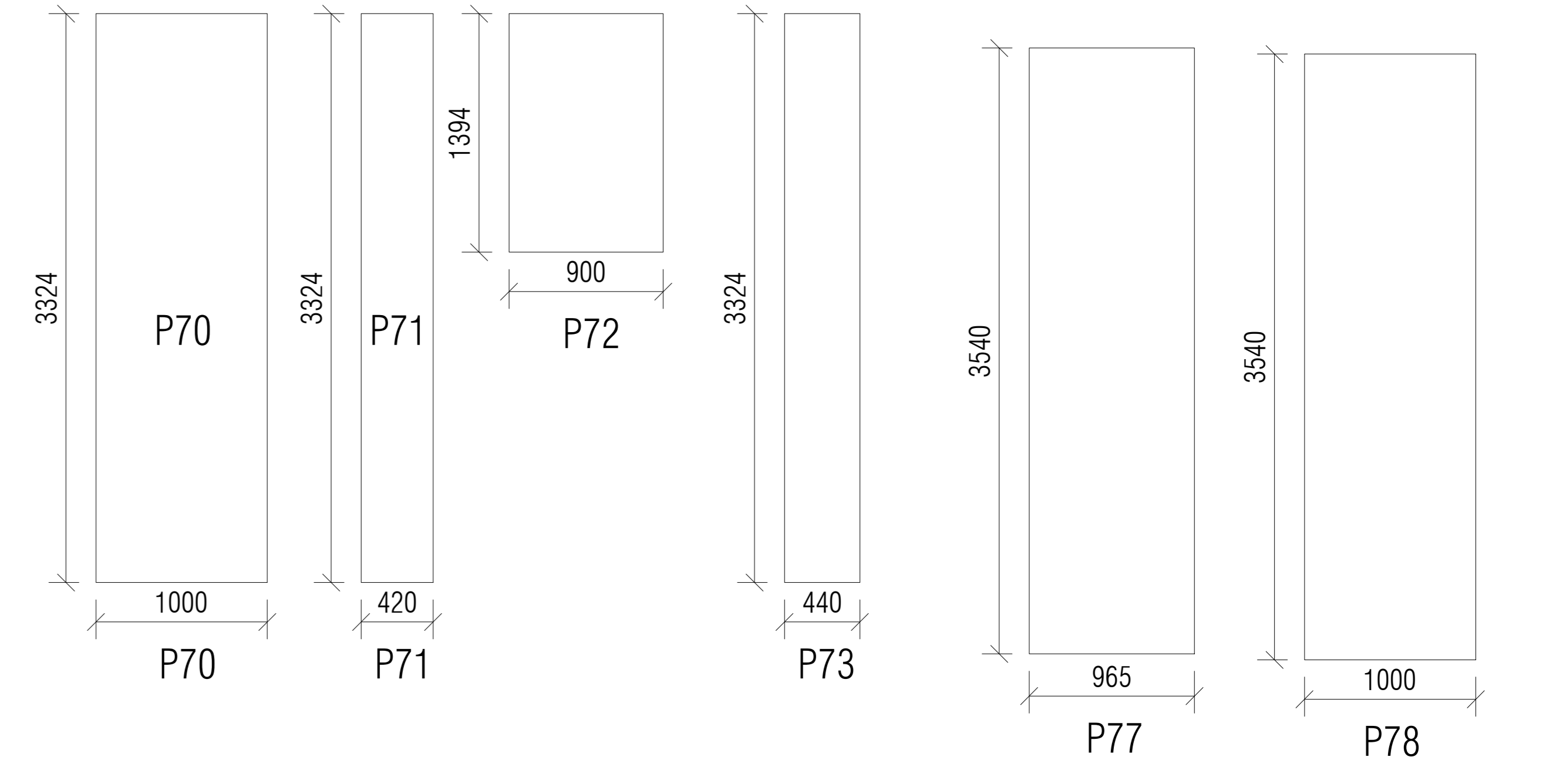
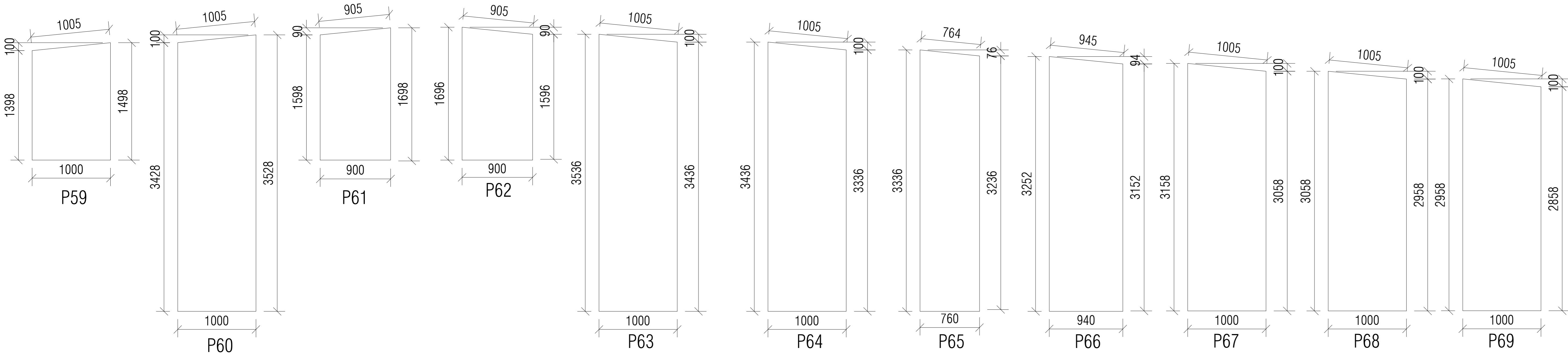

ELEVATION MARK-10
SCALE:- 1:50

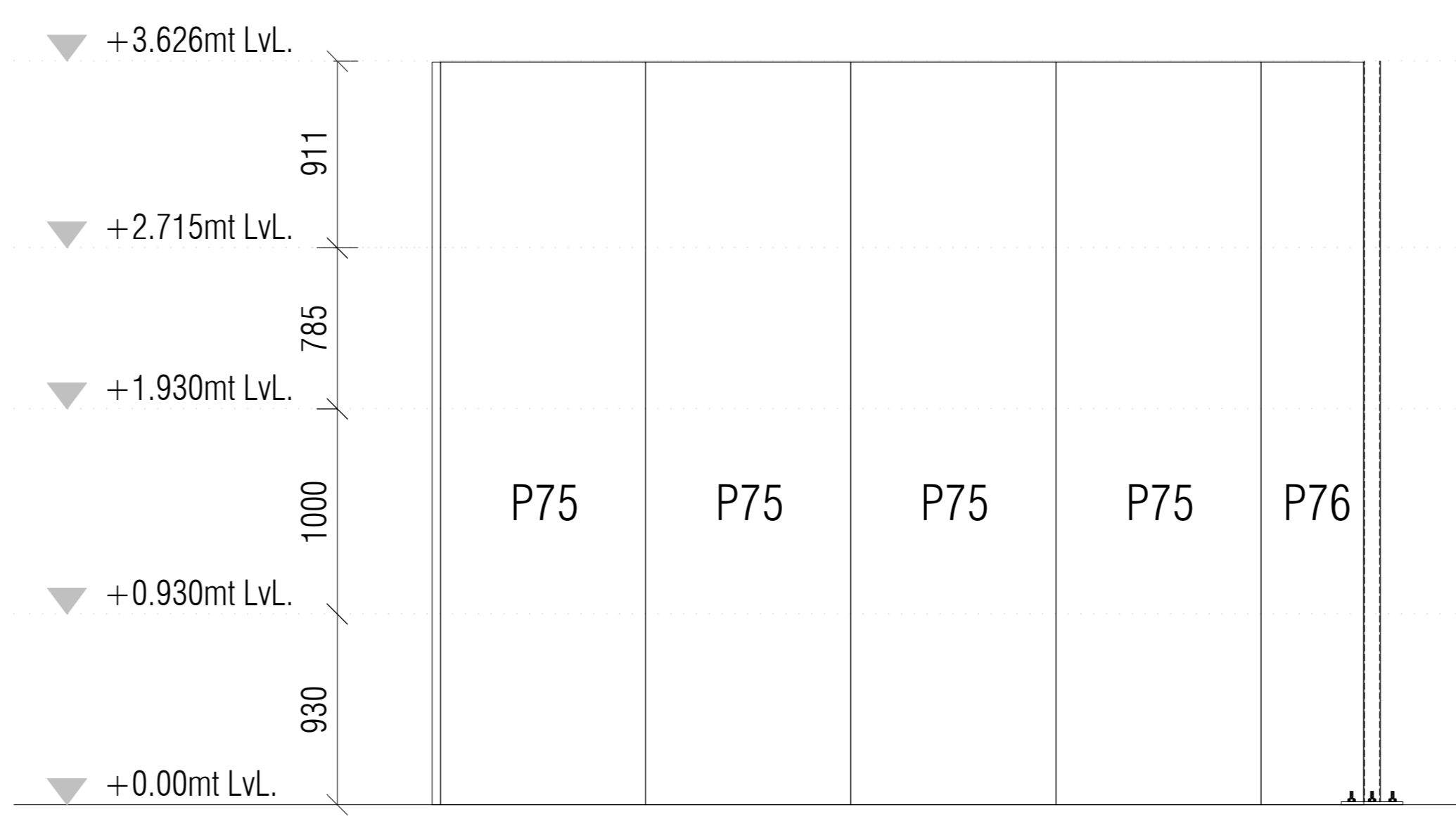
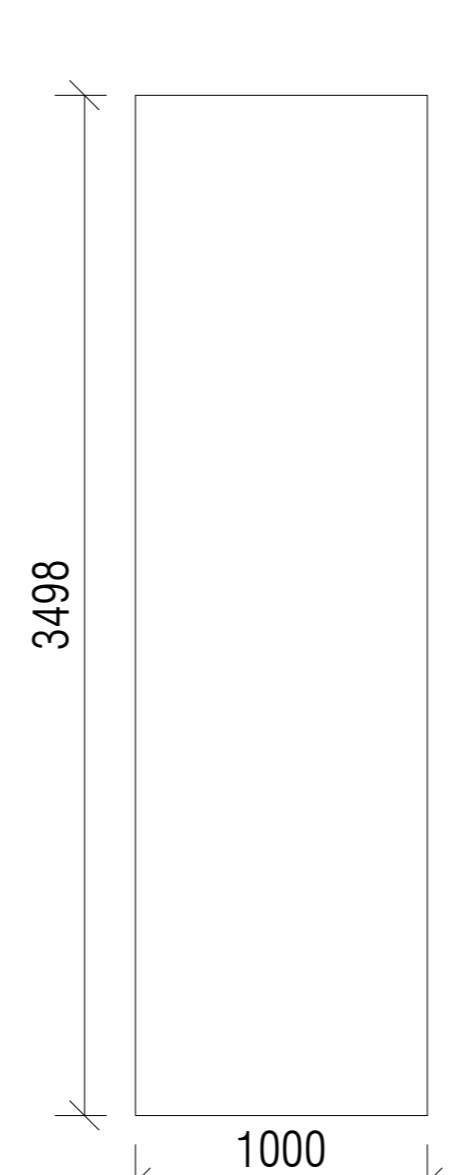

ELEVATION MARK-11
SCALE:- 1:50

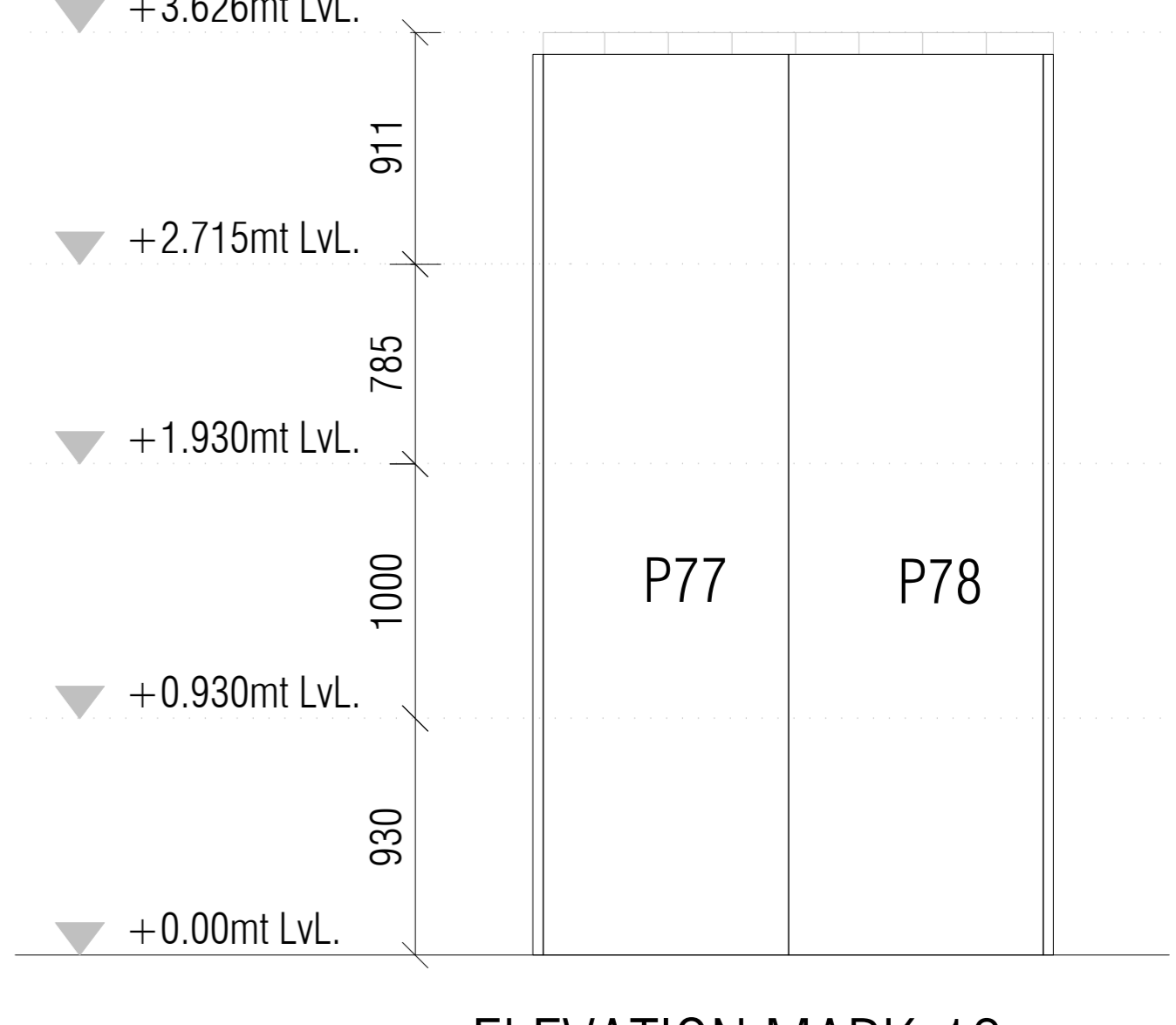
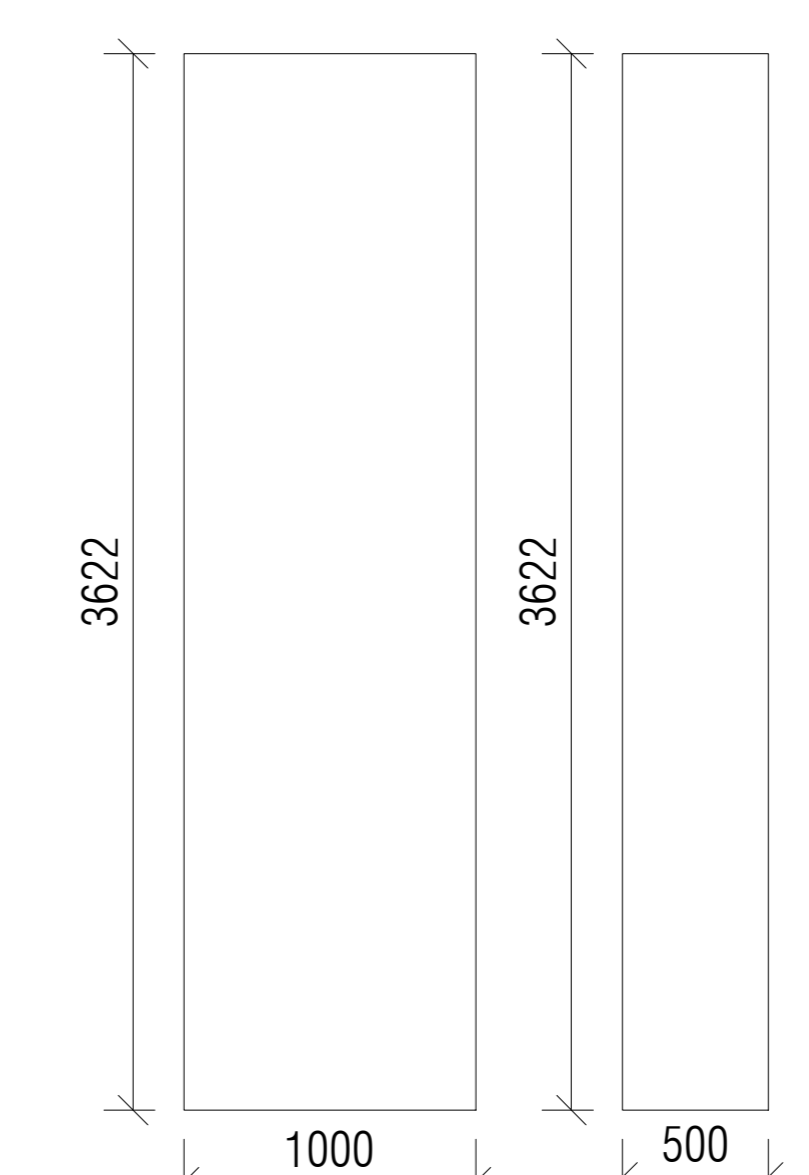

ELEVATION MARK-12
SCALE:- 1:50

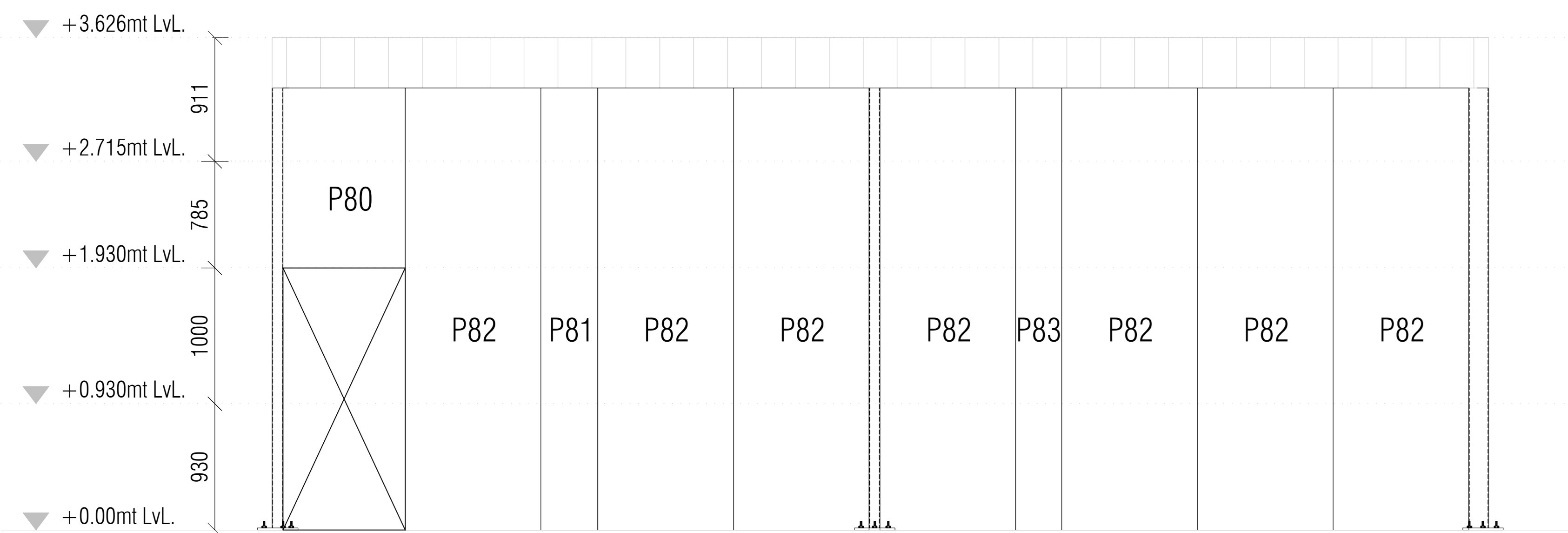

ELEVATION MARK-13
SCALE:- 1:50

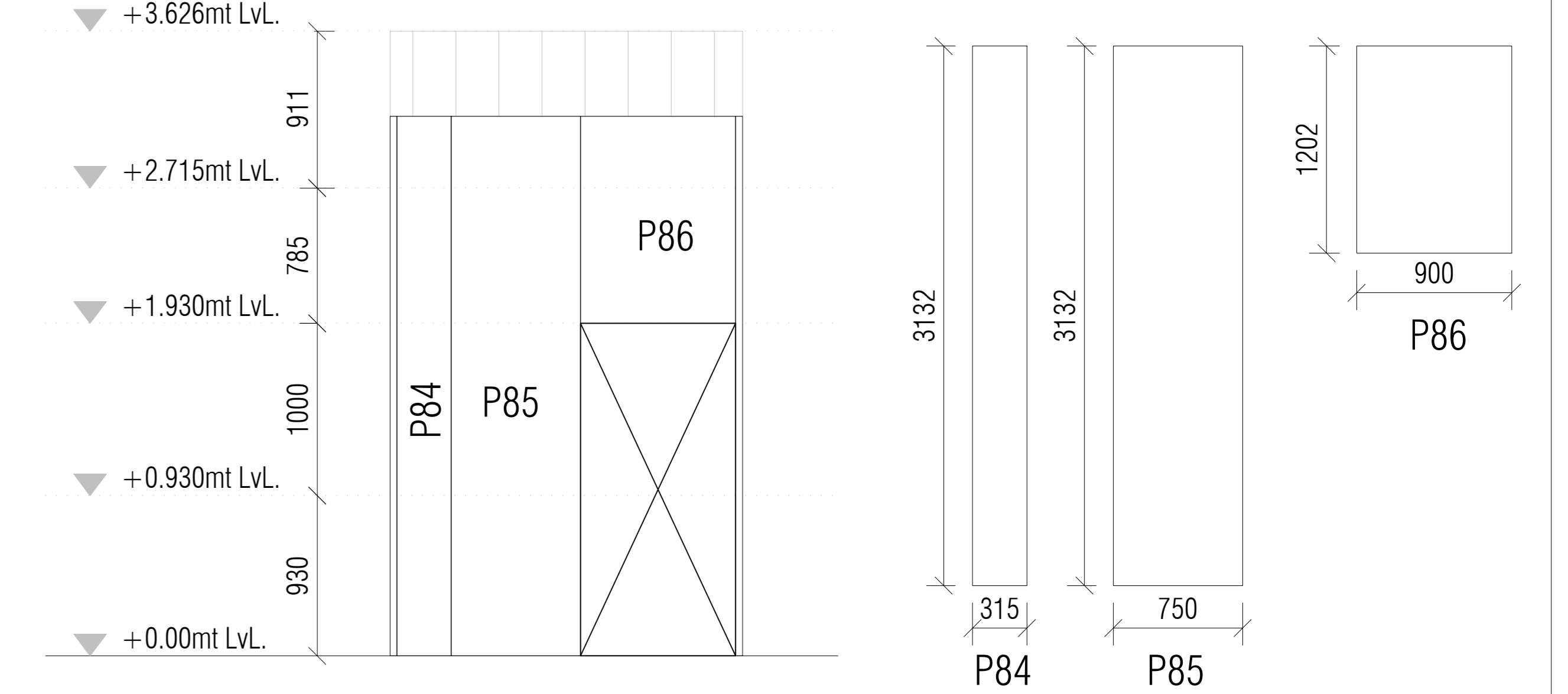
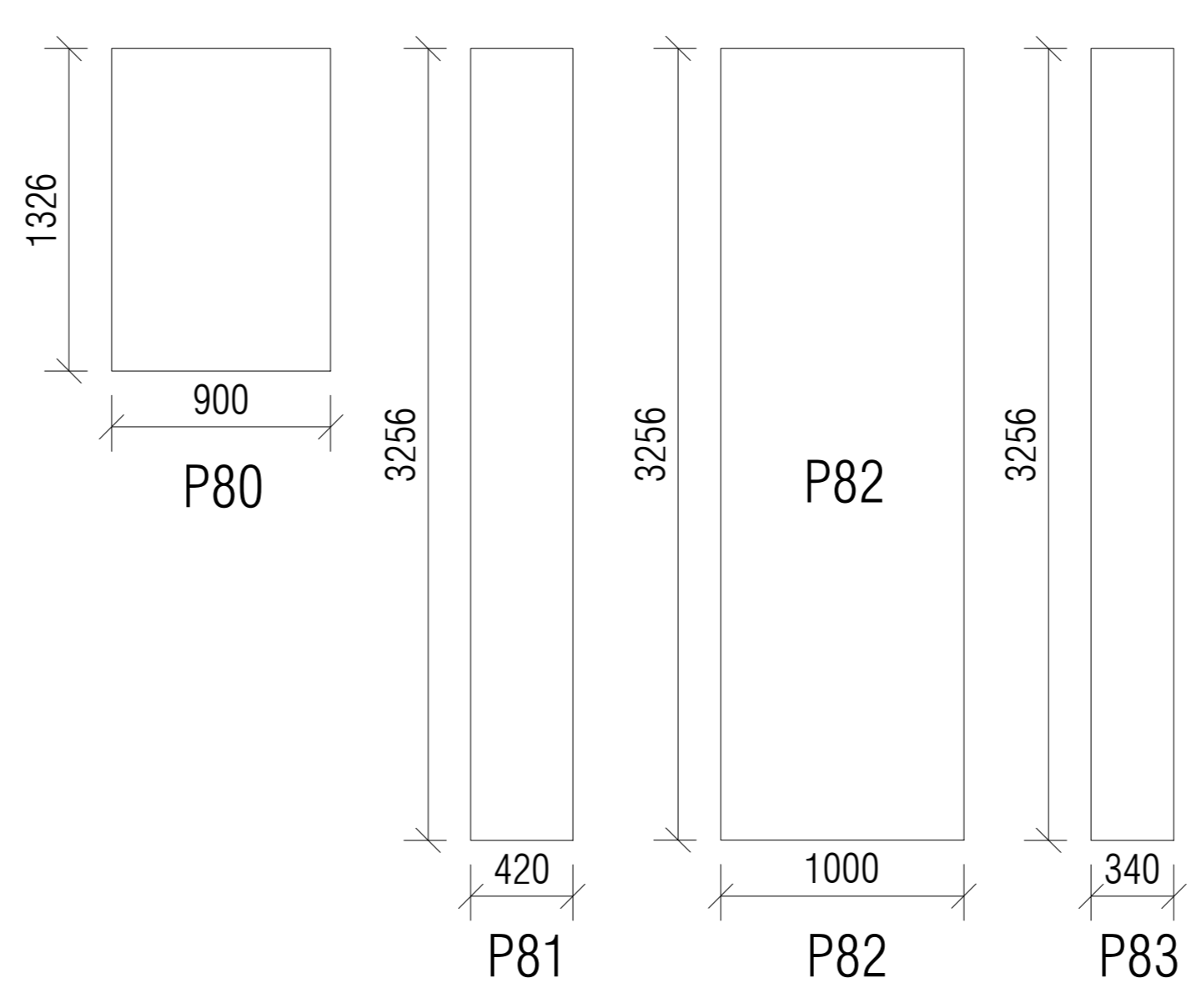

ELEVATION MARK-14
SCALE:- 1:50

| DATE:- 20-05-2015 | PROJECT:- | | CLIENT:- | DRAWING:- ELEVATION MARK - 2 |  <p>STRUCCORE ANKIT K. PATEL C/1, JAYEN APP. , CHUNIBHAI COLONY, NR. FOOTBALL GROUND , KANKARIYA, AHMEDABAD-380022 , TEL:(M) 09723618823, ankit@strucore.com</p> | DRAWING NO: AR-6.0 | | | | | | | | | | | | | | | |
|----------------------|------------------|---|------------|---------------------------------|--|-----------------------|---|------------------|------------|---|------------------|------------|--|---|---------|---------|-----------|------------|----------|------|------|
| | | <table border="1"> <thead> <tr> <th>REV.</th> <th>DESCRIPTION</th> <th>DATE</th> </tr> </thead> <tbody> <tr> <td>B</td> <td>FOR CONSTRUCTION</td> <td>20-05-2015</td> </tr> <tr> <td>A</td> <td>FOR CONSTRUCTION</td> <td>21-03-2015</td> </tr> </tbody> </table> | REV. | DESCRIPTION | | DATE | B | FOR CONSTRUCTION | 20-05-2015 | A | FOR CONSTRUCTION | 21-03-2015 | | <table border="1"> <thead> <tr> <th>SCALE:-</th> <th>DRAWN:-</th> <th>CHECKED:-</th> <th>REVISION:-</th> </tr> </thead> <tbody> <tr> <td>AS SHOWN</td> <td>K.P.</td> <td>A.P.</td> <td>A</td> </tr> </tbody> </table> | SCALE:- | DRAWN:- | CHECKED:- | REVISION:- | AS SHOWN | K.P. | A.P. |
| REV. | DESCRIPTION | DATE | | | | | | | | | | | | | | | | | | | |
| B | FOR CONSTRUCTION | 20-05-2015 | | | | | | | | | | | | | | | | | | | |
| A | FOR CONSTRUCTION | 21-03-2015 | | | | | | | | | | | | | | | | | | | |
| SCALE:- | DRAWN:- | CHECKED:- | REVISION:- | | | | | | | | | | | | | | | | | | |
| AS SHOWN | K.P. | A.P. | A | | | | | | | | | | | | | | | | | | |

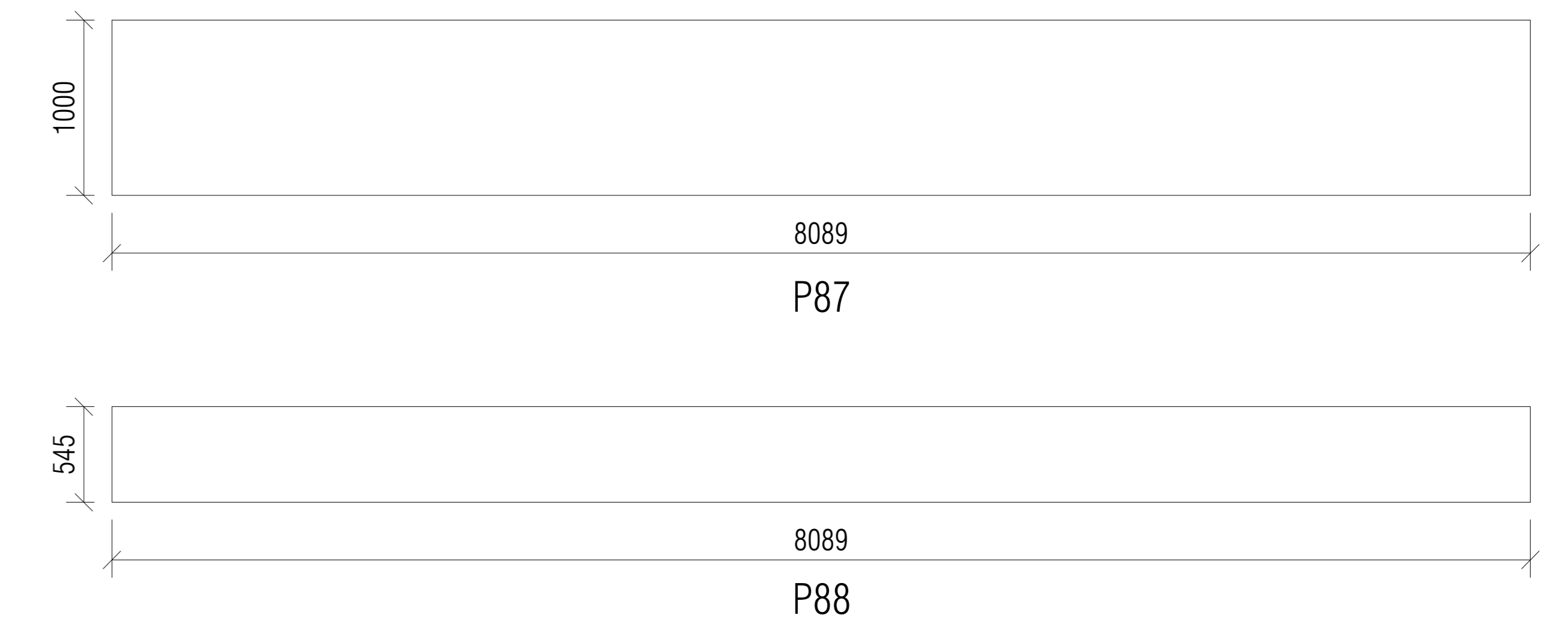
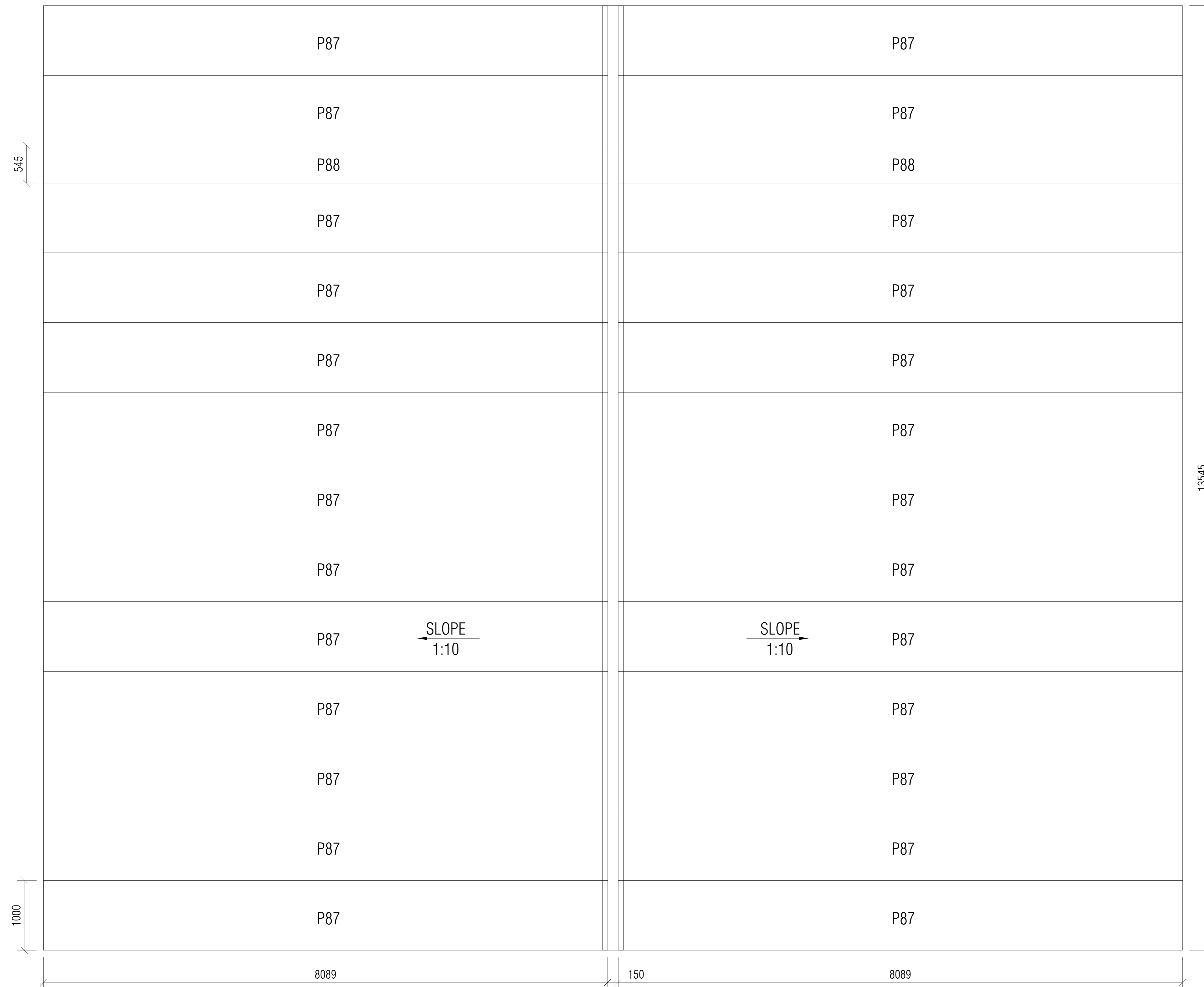

C OF RIDGE

ROOF PUFF PANEL LAYOUT

SCALE:- 1:50
(UN FOLD PLAN)

| | | | | | | | | | | | | | | | |
|----------------------|------------------|---|----------|------------------------------|---|--------------------------|------------------|--------------|------|-------------|------|--|--|--|--|
| DATE:- 20-05-2015 | PROJECT:- | | CLIENT:- | DRAWING:- TYPICAL SECTION |  <p>STRUCCORE ANKIT K. PATEL C/1, JAYEN APP. , CHUNIBHAI COLONY, NR. FOOTBALL GROUND , KANKARIYA, AHMEDABAD-380022 , TEL:(M) 09723618823, ankit@strucore.com</p> | DRAWING NO: AR-7.0 | | | | | | | | | |
| | | | | SCALE:- AS SHOWN | | DRAWN:- K.P. | CHECKED:- A.P. | REVISION:- A | | | | | | | |
| | | | | | | | | | | | | | | | |
| | | | | | | | | | | | | | | | |
| | | <table border="1"> <tr> <td>B</td> <td>FOR CONSTRUCTION</td> <td>20-05-2015</td> </tr> <tr> <td>A</td> <td>FOR CONSTRUCTION</td> <td>21-03-2015</td> </tr> <tr> <td>REV.</td> <td>DESCRIPTION</td> <td>DATE</td> </tr> </table> | B | FOR CONSTRUCTION | 20-05-2015 | A | FOR CONSTRUCTION | 21-03-2015 | REV. | DESCRIPTION | DATE | | | | |
| B | FOR CONSTRUCTION | 20-05-2015 | | | | | | | | | | | | | |
| A | FOR CONSTRUCTION | 21-03-2015 | | | | | | | | | | | | | |
| REV. | DESCRIPTION | DATE | | | | | | | | | | | | | |

| SHOP MATERIAL LIST FOR PUFF PANEL | | | |
|-----------------------------------|------------|-------------|----------------|
| MARK | WIDTH (mm) | LENGTH (mm) | TOTAL QUANTITY |
| P01 | 1000 | 2943 | 1 |
| P02 | 1000 | 3043 | 1 |
| P03 | 1000 | 3143 | 1 |
| P04 | 1000 | 3242 | 1 |
| P05 | 845 | 3328 | 1 |
| P06 | 1000 | 1498 | 1 |
| P07 | 700 | 1568 | 1 |
| P08 | 900 | 1662 | 1 |
| P09 | 1000 | 3592 | 1 |
| P10 | 205 | 3560 | 1 |
| P11 | 1000 | 3539 | 1 |
| P12 | 1000 | 1509 | 1 |
| P13 | 1000 | 930 | 2 |
| P14 | 1000 | 3339 | 1 |
| P15 | 1000 | 3239 | 1 |
| P16 | 1000 | 3139 | 1 |
| P17 | 1000 | 1109 | 1 |
| P18 | 1000 | 2939 | 1 |
| P19 | 1000 | 2000 | 15 |
| P20 | 1000 | 909 | 12 |
| P21 | 545 | 2000 | 1 |
| P22 | 1000 | 2104 | 1 |
| P23 | 650 | 2169 | 1 |
| P24 | 1000 | 1178 | 1 |
| P25 | 1000 | 2369 | 1 |
| P26 | 1000 | 2469 | 1 |
| P27 | 1000 | 2569 | 1 |
| P28 | 1000 | 1578 | 1 |
| P29 | 1000 | 2769 | 1 |
| P30 | 1000 | 2769 | 1 |
| P31 | 1000 | 2704 | 1 |
| P32 | 1000 | 1513 | 1 |
| P33 | 1000 | 2504 | 1 |
| P34 | 1000 | 2404 | 1 |
| P35 | 1000 | 2304 | 1 |
| P36 | 1000 | 1130 | 1 |
| P37 | 1000 | 2104 | 1 |
| P38 | 505 | 2000 | 1 |
| P39 | 1000 | 3602 | 1 |
| P40 | 1000 | 3602 | 1 |
| P41 | 1000 | 3550 | 1 |
| P42 | 1000 | 3450 | 1 |
| P43 | 1000 | 3350 | 1 |
| P44 | 1000 | 2958 | 2 |

| MARK | WIDTH (mm) | LENGTH (mm) | TOTAL QUANTITY |
|------|----------------------|-------------|----------------|
| P45 | 1000 | 3058 | 2 |
| P46 | 1000 | 3158 | 2 |
| P47 | 1000 | 3258 | 2 |
| P48 | 620 | 3320 | 2 |
| P49 | 240 | 3526 | 1 |
| P50 | 1000 | 3526 | 1 |
| P51 | 1000 | 1696 | 1 |
| P52 | Omitted Panel Number | | |
| P53 | Omitted Panel Number | | |
| P54 | 900 | 1326 | 2 |
| P55 | 1000 | 3166 | 2 |
| P56 | 225 | 3066 | 2 |
| P57 | 1000 | 3043 | 2 |
| P58 | 1000 | 2943 | 2 |
| P59 | 1000 | 1498 | 1 |
| P60 | 1000 | 3528 | 1 |
| P61 | 900 | 1698 | 1 |
| P62 | 900 | 1696 | 1 |
| P63 | 1000 | 3536 | 1 |
| P64 | 1000 | 3436 | 1 |
| P65 | 760 | 3336 | 1 |
| P66 | 940 | 3252 | 1 |
| P67 | 1000 | 3158 | 1 |
| P68 | 1000 | 3058 | 1 |
| P69 | 1000 | 2958 | 1 |
| P70 | 1000 | 3324 | 6 |
| P71 | 420 | 3324 | 1 |
| P72 | 900 | 1394 | 2 |
| P73 | 440 | 3324 | 1 |
| P74 | 1000 | 3498 | 7 |
| P75 | 1000 | 3622 | 4 |
| P76 | 500 | 3622 | 1 |
| P77 | 965 | 3540 | 1 |
| P78 | 1000 | 3540 | 1 |
| P79 | Omitted Panel Number | | |
| P80 | 900 | 1326 | 1 |
| P81 | 420 | 3256 | 1 |
| P82 | 1000 | 3256 | 7 |
| P83 | 900 | 1326 | 1 |
| P84 | 340 | 3256 | 1 |
| P85 | 315 | 3132 | 1 |
| P86 | 900 | 1202 | 1 |
| P87 | 1000 | 8089 | 26 |
| P88 | 545 | 8089 | 2 |